



Model 150 m³/h (90 cfm)



OVERVIEW :

It is a mechanical backing vacuum pump which is able to extract and transfer gases with an ultimate vacuum of $5 \cdot 10^{-1}$ mbar. The outlet pressure can reach 2500 mbar with gases such as UF₆. It is equipped with cooling circuit, with thermal control system and, for some applications, with an oil heater. The various working parts of the pump are designed to provide a long service life.

OPERATING PRINCIPAL :

The pumping device is made up of 2 overlapped scrolls ; one of them is moving and the other one is fixed. The movement is provided by 3 cranks-hafts (one is driving) with the same eccentricity. This movement causes the formation of chambers between the two spiral vanes. Once these chambers are formed, they remain closed, and as a result of the movement of one vane, they are progressively, continuously reduced in size and displaced towards a central exhaust port.

In normal operation, varying pumping conditions produce varying thermal transfers. To prevent these variations resulting in differential expansion likely to produce a dangerous reduction in the clearance between the vanes, the pump is subject to the action of a thermal control and safety system for the lubricating oil and cooling water circuits which are designed to produce even and uniform temperatures of the various component parts of the pump.

APPLICATIONS :

These pumps are used all over the world to circulate all kind of gases which can be aggressive, inert, toxic or radioactive (the only materials exposed to the vacuum environment are 304L stainless steel, nickel plated steel and the metal that you choose for the seals). For instance, our model 150 m³/h is used for pumping corrosive gases like UF₆, ClF₃, HF for uranium enrichment industry.

BENEFITS :

- Completely dry and fluid tight vacuum pump
- Safety (double confinement bellows, electrical safety devices), reliability
- Maintenance is carried out without opening of the vacuum circuit
- Low running and maintenance cost (no liquid nitrogen, long service life)
- Low noise and vibration level

TECHNICAL DATA :

Displacement (50 Hz operation) :	150 m ³ /h (90 ft ³ .min ⁻¹)
Peak pumping speed (50 Hz operation) :	120 m ³ /h (70.7 ft ³ .min ⁻¹)
Ultimate vacuum :	5.10 ⁻¹ mbar
Connections :	Meeting your need
Motor power	4 kW
Enclosure rating	IP 55
Motor voltage :	230-400 V
• 3-phase 50 Hz	220-440 V
• 3-phase 60 Hz	On application
Other voltage	1250 kg (2750 lb)
Weight	< 10 ⁻⁸ mbar.l.s ⁻¹
Leak tightness (helium)	

PERFORMANCES :

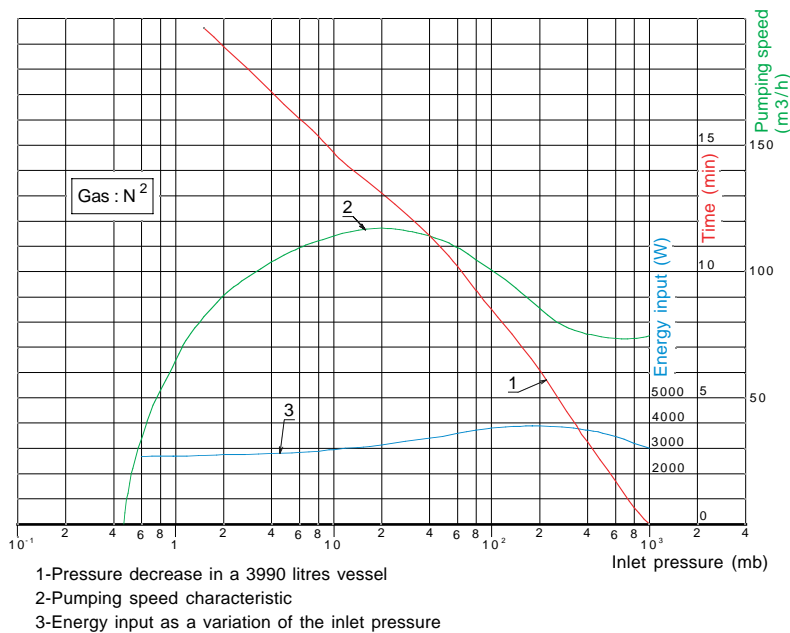

DIMENSIONS (in millimeters) :

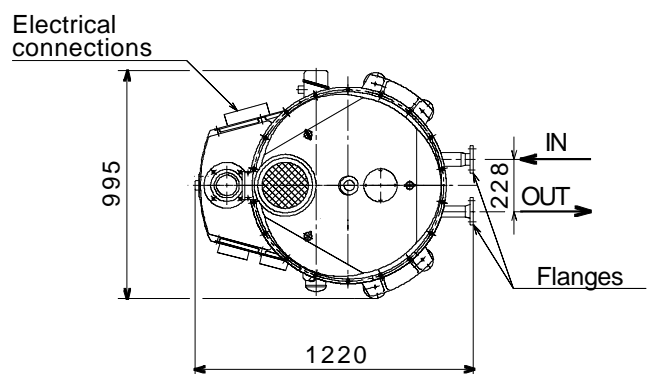
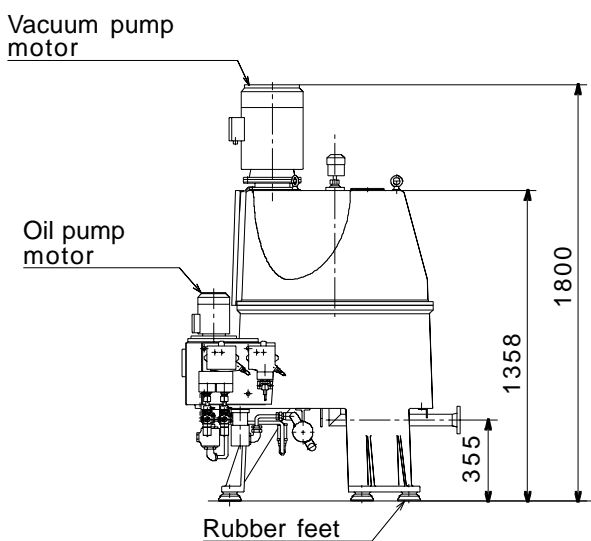

Pump connections must not be rigid type (bellows,...)



Your Authorized Distributor is: Stultz USA
 1-706-925-1220
 www.StultzUSA.com
 Email: rfq@stultzusa.com